

WARNING: If the information in this manual is not followed exactly, a fire or explosion may result causing property damage, personal injury or death.

- Do not store or use gasoline or other flammable vapors and liquids in the vicinity of this or any other appliance.
- **WHAT TO DO IF YOU SMELL GAS**
 - Do not try to light any appliance.
 - Do not touch any electrical switch; do not use any phone in your building.
 - Immediately call your gas supplier from a neighbor's phone. Follow the gas supplier's instructions.
 - If you cannot reach your gas supplier, call the fire department.
- Installation and service must be performed by a qualified installer, service agency or the gas supplier.

FOR FUTURE REFERENCE

Should you have any questions about using your Maytag gas range, call or write us. Be sure to provide the model number of your range.

CONSUMER EDUCATION
MAYTAG COMPANY
ONE DEPENDABILITY SQUARE
NEWTON, IOWA 50208
(515) 791-8911
(Mon. - Fri. 8 am - 5 pm CST)

For future reference we suggest you retain this manual after recording the model number and serial number of this gas range in the spaces provided. This information can be found on the data plate located on the left side of the frame around the storage drawer.

Model Number

Serial Number

Date Purchased

IMPORTANT: Retain the proof of purchase documents for warranty service.

WARNING - Check with the installer to make sure the appliance has been grounded to avoid possible electrical shock. Be sure you read the IMPORTANT SAFETY INSTRUCTIONS on page 2 before you start to use this range.



WARNING

- ALL RANGES CAN TIP
- INJURY TO PERSONS COULD RESULT
- INSTALL ANTI-TIP DEVICES PACKED WITH RANGE
- SEE INSTALLATION INSTRUCTIONS

TABLE OF CONTENTS

	Page
For Future Reference	Inside Front Cover
Important Safety Instructions	2-4
Range Control Panel	5
Electronic Clock	5-6
• Setting the Clock and Timer	6
Surface Cooking	6-9
• Sealed Gas Burners.....	6-8
• Cookware Considerations.....	9
Using Your Oven	10-17
• Baking.....	11-13
• Roasting.....	14
• Broiling.....	15
• Delay Start Oven Cooking.....	16-17
Care and Cleaning	17-19
• Sealed Gas Burners and Cooktop	17
• Continuous Clean Oven	18
• Manual Clean Oven	18
• Range Cleaning Chart	19-20
Maintenance	21-23
• Electrical Connection	21
• Leveling Legs	21
• Light Replacement	21-22
• Oven Door.....	22
• Proportional Valve Adjustment	22
• Removing Range for Cleaning and Servicing.....	23
• Broiler Drawer	23
Before You Call for Service	24
Consumer Publications	25
Warranty	Back Cover

IMPORTANT SAFETY INSTRUCTIONS

General

No cooking appliance should be used as a space heater. This instruction is based on safety considerations to prevent potential hazard to the consumer as well as damage to the appliance.

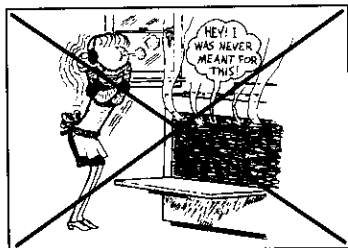

If the range is installed near a window, proper precautions should be taken to prevent the curtains from blowing over the burners creating a FIRE HAZARD.

Keep the area around the appliance clear and free from combustible materials, gasoline, and other flammable vapors and materials.

Have the installer show you the location of the gas shut off valve and how to shut it off in an emergency.

Your appliance is vented through the base of the backguard. Never block the oven vent or the air intakes. Do not obstruct the flow of the combustion and ventilation air. Restriction of the air flow to the burner prevents proper performance.

Avoid touching the oven vent area while oven is on and for several minutes after the oven is turned off. Some parts of the vent and the surrounding area can become hot enough to cause burns.

Do not use the cooktop or the oven as a storage area for food or cooking utensils. This instruction is based on safety considerations to prevent a potential hazard to the user and to the appliance.

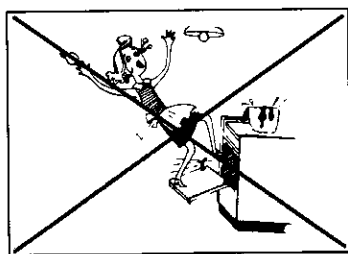

breakage of the door and serious injuries.

Misuse of the appliance door, such as stepping, leaning or sitting on the door, may result in possible tipping of the appliance or

In Case of Fire:

1. Turn off the range controls.
2. Smother the fire or flame with baking soda, dry chemical, or a foam-type extinguisher. Do not use water on grease fires.

Child Safety

Do not leave children alone or unsupervised near the appliance when it is in use or is still hot. Children should never be allowed to sit or stand on any part of the appliance. Children must be taught that the appliance and utensils in it can be hot. Children should be taught that an appliance is not a toy. They should not be allowed to play with controls or other parts of the unit. Let hot utensils cool in a safe place, out of reach of small children.



CAUTION: Do not store items of interest to children in cabinets above an appliance or on the backguard of a range. Children climbing on the appliance to reach items could be seriously injured. Do not use an appliance as a step stool to any cabinets above.

Anti-Tip Device

To reduce the risk of tipping of the appliance from unusual usage or by excessive loading of the oven door, the appliance must be secured by a properly installed anti-tip device. To check if device is installed properly, use a flashlight and look underneath the range to see that one of the rear leveling legs is engaged in the bracket slot. When removing the appliance for cleaning, be sure the anti-tip device is engaged when the range is replaced. The anti-tip device secures the rear leveling leg to the floor, when properly engaged.

Cleaning

Turn off all the controls and wait for the range parts to cool before touching or cleaning them. Do not touch the burner grates or surrounding areas until they have had sufficient time to cool.

Touching a hot oven light bulb with a damp cloth could cause the bulb to break. Should the bulb break, disconnect the power to the range before trying to remove the bulb to avoid electrical shock.

Clean the range with caution. If a wet sponge or cloth is used to wipe spills on a hot cooking area, be careful to avoid steam burns. Some cleaners can produce noxious fumes if applied to a hot surface.

Grease

Use extreme caution when moving the grease kettle or disposing of hot grease.

Hot grease is flammable. Avoid letting grease deposits collect around the appliance, range hood, or vent fan. Do not leave a container of grease around a cooking appliance. Always let quantities of hot fat used for deep fat frying cool before attempting to move or handle. In the event of a grease fire, **DO NOT** attempt to move the pan. Cover the pan with a lid to extinguish the flame and turn the surface burner off. Do not douse the flame with water. Use a dry chemical or foam-type fire extinguisher, if available, or sprinkle heavily with baking soda.

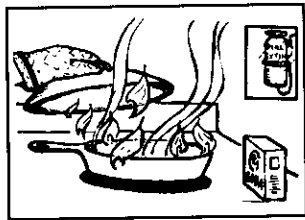

Spills or boilovers which contain grease should be cleaned up as soon as possible. If they are allowed to accumulate, they could create a **FIRE HAZARD**.

Prepared Food Warning

Follow the food manufacturer's instructions.

If a plastic frozen food container and/or its film cover distorts, warps or is otherwise damaged during cooking, immediately discard the food and its container. The food could be contaminated.

Cooking Safety

Always adjust the surface burner's flame so that it does not extend beyond the bottom of the utensil. This instruction is based on safety considerations.

Never leave a surface cooking operation unattended especially when using a high heat setting. Boilovers can cause smoking and greasy

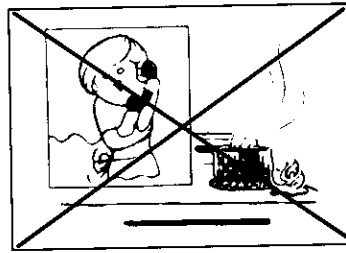

spillovers may ignite.

Be sure you know which knob controls which surface burner. Always make sure the correct burner

is turned on and that the burner has ignited. When cooking is completed, turn the burner off.

Use caution when wearing garments made of flammable material to avoid clothing fires. Loose fitting or long hanging-sleeved apparel should not be worn while cooking. Clothing may ignite or catch utensil handles.

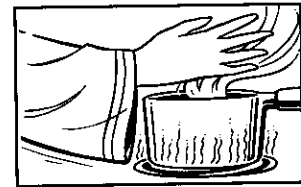

Never heat an unopened container on the surface burner or in the oven. Pressure build-up may cause the container to burst resulting in serious personal injury or damage to the range.

Slide the oven rack out to add or remove food, using dry, sturdy pot holders. Always avoid reaching into the oven to place or remove food.

Use dry, sturdy pot holders. Damp pot holders may cause burns from steam. Dish towels or other substitutes should never be used as pot holders because they can trail across the hot surface burners and ignite or get caught on range parts.

Use care when opening the oven door. Let any hot air or steam escape before removing or replacing the food. Always place the oven racks in the desired positions while the oven is cool. If a rack must be moved while hot, be careful to avoid contact of the pot holders with the oven burner flame.

Storage Above the Range

To eliminate the hazard of reaching over hot surface burners, cabinet storage should not be provided directly above a unit. If such storage is provided, it should be limited to items which are used infrequently and which are safely stored in an area subjected to heat from an appliance. Temperatures in the storage areas above the unit may be unsafe for some items, such as volatile liquids, cleaners or aerosol sprays.

Utensil Safety

Use only pans that have flat bottoms and handles that are easily grasped and stay cool. Avoid using unstable, warped, easily tipped or loose handled pans. Do not use pans if their handles twist and cannot be tightened. Pans that are heavy to move when filled with food may also be hazardous.

Always place a pan of food on a surface burner before turning it on and turn it off before removing the pan.

Always turn pan handles to the side or back of the appliance, not out into the room where they are easily hit or reached by small

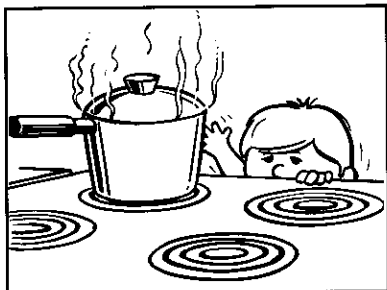

children. To minimize burns, ignition of flammable materials and spillage due to unintentional contact with the utensil, do not extend handles over the adjacent surface burners.

Be sure the utensil is large enough to properly contain food and avoid boilovers. The pan size is particularly important in deep fat frying. Be sure the pan will accommodate the volume of food that is to be added as well as the bubble action of the fat. Never leave a deep fat frying operation unattended.

Never let a pan boil dry as this could damage the utensil and the appliance.

Aluminum Foil

Use aluminum foil **ONLY** as instructed in this book. Improper use of aluminum foil may cause damage to the oven, affect the cooking results, and can also result in shock and/or fire hazards.

Plastics

Many plastics are vulnerable to heat. Keep plastics away from the parts of the appliance that may become warm or hot.

Aerosol Sprays

Many aerosol-type spray cans are **EXPLOSIVE** when exposed to heat and may be highly

flammable. Avoid their use or storage near an appliance.

Self-Clean Oven (select models)

Do not clean the door gasket. The door gasket is essential for a good seal. Care should be taken not to rub, damage, or move the gasket. Do not use oven cleaners of any kind in or around any part of the self-clean oven. Clean only the parts listed in this booklet. Before self-cleaning the oven, remove the broiler pan, oven racks, and other utensils, and wipe off excessive spillovers.

It is normal for the cooktop of the range to become hot during a self-clean cycle. Therefore, touching or lifting the cooktop during a clean cycle should be avoided.

Important Safety Notice and Warning

The California Safe Drinking Water and Toxic Enforcement Act of 1986 (Proposition 65) requires the Governor of California to publish a list of substances known to the State of California to cause cancer or reproductive harm, and requires businesses to warn customers of the potential exposures to such substances.

Users of this appliance are hereby warned that the burning of gas can result in low-level exposure to some of the listed substances, including benzene, formaldehyde and soot, due primarily to the incomplete combustion of natural gas or liquid petroleum (LP) fuels. Properly adjusted burners will minimize incomplete combustion. Exposure to these substances can also be minimized by properly venting the burners to the outdoors.

Ventilating Hood

To reduce the hazard of storage above a range, install a ventilating hood that projects at least five inches beyond the bottom edge of the cabinets. Clean the hood frequently to prevent grease from accumulating on the hood or its filter. Should a boilover or spillover result in an open flame, immediately turn off the hood's fan to avoid spreading the flame. After thoroughly extinguishing the flame, the fan may be turned on to remove any unpleasant odor or smoke.

SAVE THESE INSTRUCTIONS

RANGE CONTROL PANEL

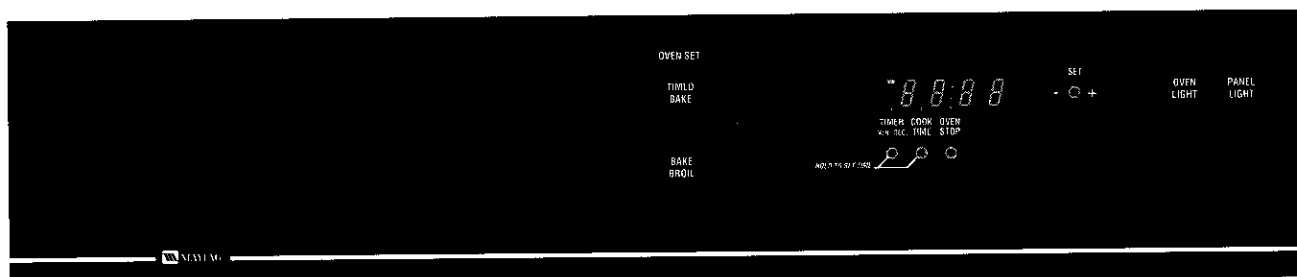

Styling may differ depending on the model you selected.

ELECTRONIC CLOCK



The electronic clock on your Maytag range is used for the time-of-day clock, timer and delay start functions. At the end of an operation, consecutive beeps will sound.

The display on the control will blink when power is first supplied to the range or if there is a power failure. Once the time-of-day clock has been set (see *Setting the Clock*, page 6), the display will stop blinking.

The following buttons and knobs are found on your Maytag electronic clock:

Set Knob

Turn this knob in either direction to enter the time for all functions.

Timer Button

The timer can be set from 1 second to 99 minutes. See page 6 for instructions on setting the timer.

Cook Time / Oven Stop Buttons

These buttons are used to program the oven to start and stop automatically, either immediately or at a later time. For detailed information on using Delay Start, see pages 16-17.

Setting the Clock and Timer

Clock

To set the time-of-day clock:

1. Press the **TIMER** and **COOK TIME** buttons at the same time and hold down while setting the clock.
2. Turn the **SET** knob in either direction to the correct time-of-day. Release the **TIMER** and **COOK TIME** buttons.

Timer

To set the timer:

1. Press the **TIMER** button once. The ▼ triangular indicator will light in the display above the **TIMER** button.
2. Turn the **SET** knob to the desired time. For example, turn the display to 0:05 for five seconds or to 5:00 for five minutes. The timer will start automatically. The signal will beep when the time elapses and continue to beep until the **TIMER** button is pressed.

To cancel the timer: turn the **SET** knob until the display reads 0:00.

SURFACE COOKING

Sealed Gas Burners

NOTE: The cooktop and surface burners on your Maytag gas range are considerably different from a conventional gas range. To insure proper and efficient use of all its features, please take a few minutes to read these instructions and become familiar with its operation.

Cooktop

The cooktop on gas ranges with sealed burners is designed with two contoured wells which contain spills until they can be wiped up. Unlike a range with standard gas burners, **this cooktop does not lift-up nor is it removable.** To prevent damage to the range, do not attempt to lift the cooktop for any reason.

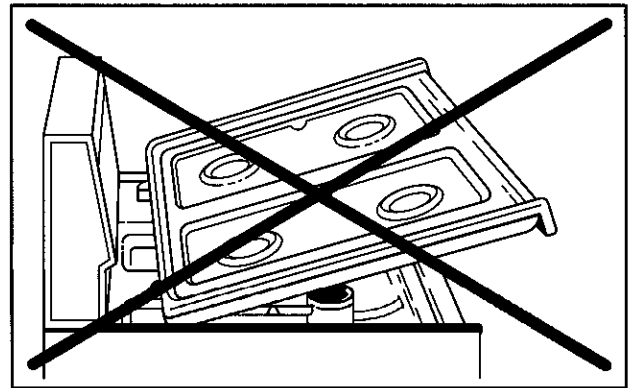

Square Burner Grates

CAUTION: The burner grates must be properly positioned before cooking. Do not operate the burners without a pan on the grate. The grate's porcelain finish may chip without a pan to absorb the intense heat from the burner flame.

When reinstalling the square grates, place the indented sides together so the straight sides are at the front and rear. Although the burner grates are durable, they will gradually lose their shine due to high temperatures.

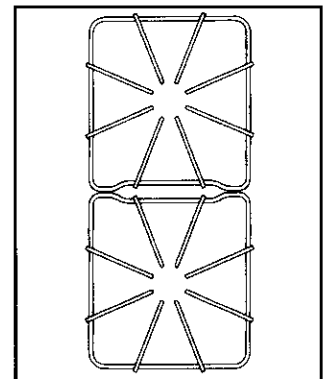

Sealed Burners

The four sealed burners of your Maytag range are secured to the cooktop and are **not** designed to be removed.

Since the four burners are sealed into the cooktop, boilovers or spills won't seep underneath the cooktop. Thus, there are no hidden spills in the burner box area to clean.

Your range features two special **Power Burners** located in the left rear and right front positions. These offer higher speed cooking that can be used to quickly bring water to a boil and for large-quantity cooking.

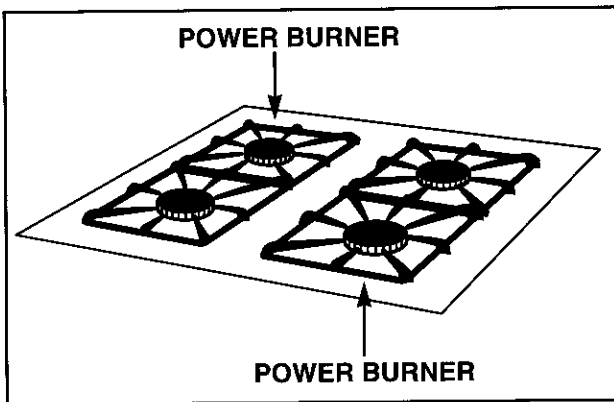

A properly adjusted burner with clean ports will light within a few seconds. If using natural gas, the flame will be blue with a deeper blue inner core; there should be no trace of yellow in the flame (this indicates an improper mixture of air/gas which wastes fuel and should be adjusted by a service technician) With LP gas, some yellow tips on the flames are acceptable. This is normal and adjustment is not necessary.

With some types of gas, you may hear a "popping" sound when the surface burner is turned off. This is a normal operating sound of the burner.

Pilotless Ignition

Be sure all surface controls are set in the OFF position prior to supplying gas to the range.

Your range is equipped with a pilotless ignition system which eliminates the need for a constant standing pilot light. The spark igniter is located at the back-side of each burner. When cleaning around the surface burner, use care. If a cleaning cloth should catch the igniter, it could damage or break it. This will prevent the burner from lighting.

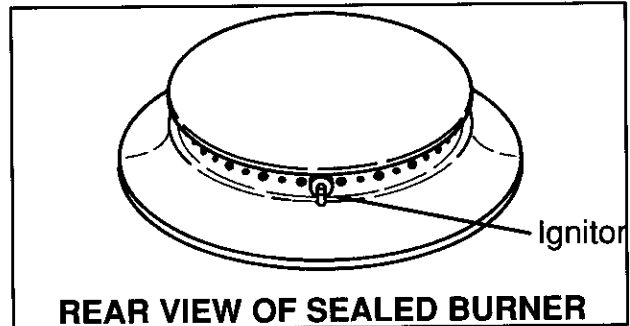

Lighting the Surface Burners

To light the surface burners:

1. Place a pan on the burner grate.
2. Push in and turn the knob to the **START** position. A sparking sound will be heard and the burner will light.

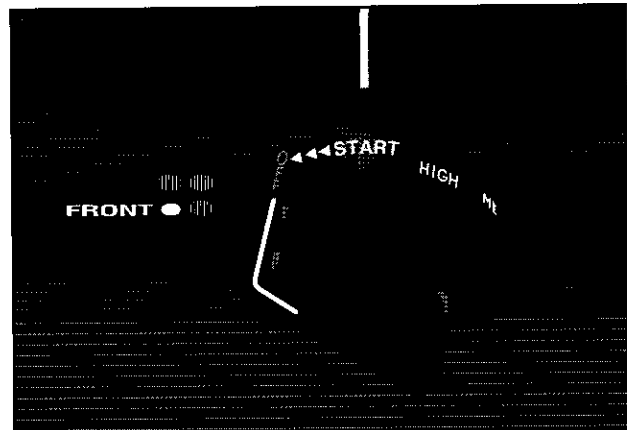

NOTE: All four igniters will spark when any surface burner knob is turned to the **START** position.

3. Once the burner lights, turn the knob to the desired flame size. The sparking will not stop until the knob is turned from the **START** position.

Selecting the Flame Size

If a knob is turned very quickly from HIGH to WARM, the flame may go out, particularly if the burner is cold. If this occurs, turn the knob to the OFF position. Wait several seconds, then light the burner again.

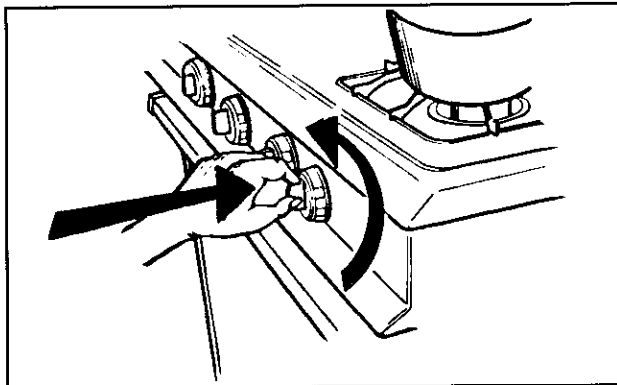

The flame should be adjusted so it does not extend beyond the edge of the cooking utensil. This improves your cooking efficiency, insures your personal safety and prevents damage to any cabinets above the range.

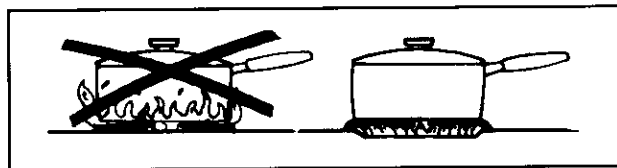

Flame Setting	Uses
HIGH	Use to quickly bring foods to a boil or to begin a cooking operation. Reduce to a lower setting to continue cooking. Never leave food unattended when using a HIGH flame setting.
MEDIUM	Use this setting to continue a cooking operation. Food will not cook any faster when a higher flame setting is used than needed to maintain a gentle boil.
WARM	Use to simmer or keep foods at serving temperatures. Some cooking may take place if the utensil is covered.

CAUTION: If the flame should go out during a cooking operation, turn the burner to the OFF position. **If gas has accumulated and a strong gas odor is detected, wait five minutes for the gas odor to disappear before relighting the burner.**

Operating During Power Failure

To operate one or more of the surface burners during a power failure:

1. Hold a lighted match to the desired surface burner head.
2. Turn the control knob to START. The burner will then light.
3. Adjust the flame to the desired level.

CAUTION: When lighting the surface burners, be sure all of the controls are in the OFF position. Strike the match first and hold it in position before turning the knob to START.

Cookware Considerations

The cookware material, construction and size can play a large role in cooking performance. Proper utensils will reduce cooking times, use less energy and cook food more evenly.

Optimum cooking performance can be achieved when heavy gauge, flat, smooth bottom, metal utensils with straight sides and tight fitting lids are used. When selecting cookware, consider the following things.

Construction and Size

For best heat conduction from the gas burner to the utensil, use flat bottom utensils. To determine the flatness of the bottom of a pan, place the edge of a ruler across the bottom of the utensil. Hold it up to the light. Little or no light should be visible under the ruler.

The flame size should be adjusted so it does not extend beyond the edge of the cooking utensil. This is for personal safety and to prevent damage to the range and any cabinets installed above it.

Material

The pan material determines how evenly and quickly heat is transferred from the gas burner to the pan bottom. Some widely used pan materials are:

Aluminum	Excellent heat conductor. Some food will cause it to darken or pit. Anodizing improves stain resistance. Often used as a bottom coating to improve the heating of other pan materials.
Copper	Excellent heat conductor. Discolors easily, requires constant polishing. Often used as a bottom coating to improve the heating of other pan materials.
Stainless Steel	Slow heat conductor. Develops hot spots and produces uneven cooking results. Durable, attractive, easy to clean and stain resistant. Will distribute heat better if other metals (aluminum or copper) are combined or sandwiched together as a bottom coating.
Cast Iron	Slow heat conductor. Cooks evenly once temperature is reached. Heavy. Needs seasoning to make cleaning easier and to prevent sticking and rusting.
Glass, Ceramic or Glass-Ceramic	Slow heat conductors. Easy to clean. Some types may only be used in the oven.
Porcelain-Enamel	Glass-like substance fused to metal. Heating characteristics depend on base material (usually aluminum, stainless steel, carbon steel or cast iron). Available in colors and easy to clean.

Note: Some brands of metal, smooth bottom cookware that generally perform well on all types of ranges are Farberware, Magnalite, Revere Ware, Wearever, T-Fal, and smooth bottom Club Aluminum®.

*Brand names are the trademarks of respective manufacturers.

Canning

Acceptable water-bath or pressure canners should not be oversized and must have a flat bottom. The following are **not recommended:** canners with ridged bottoms, oversized canners or a very large canner that rests on two surface burner grates.

When canning, use the High setting just until the water comes to a boil or pressure is reached in the pressure canner, then reduce to the lowest heat setting that maintains the boil or pressure.

Prolonged use of the High setting or the use of incorrect canning utensils will produce excessive heat. Excessive heat can cause permanent damage to the range.

For more information on canning procedures, contact your local county extension office or one of the following companies who specialize in home canning:

- Ball Corporation
Consumer Affairs Department
345 South High St.
Muncie, IN 47305-2326
- Kerr Glass Manufacturing Corporation
Consumer Products Division
1840 Century Park East
Los Angeles, CA 90067

USING YOUR OVEN

Pilotless Ignition

With this type of ignition system, **the oven will not operate during a power failure or if the oven is disconnected from the wall outlet.** No attempt should be made to operate the oven during a power failure.

Every oven has its own characteristics. You may find that the cooking times and temperatures you were accustomed to with your previous range may need to be altered slightly with the new range. Compare your recipes with the baking chart on page 12 or refer to a reliable cookbook for proper recommendations. It is normal to notice some differences between this appliance and your old one.

Setting the Controls

The OVEN TEMP knob is used to select and maintain the oven temperature. Always turn this knob just to the desired temperature – not to a higher temperature and then back. This provides more accurate oven temperatures. Turn this knob fully counterclockwise whenever the oven is not in use. The OVEN SET switch on the back panel determines the type of oven operation.

To set your oven for baking or roasting:

1. When cool, position the racks in the oven according to what you are baking.
2. Turn the OVEN TEMP knob to the desired oven temperature.
3. Depress the OVEN SET switch to the Bake/Broil position. Allow 10-15 minutes for preheating.
4. Place the food in the center of the oven, allowing a minimum of two inches between the utensil(s) and the oven walls.
5. Check the food for doneness at the minimum time given in the recipe. Cook longer if necessary. Turn the OVEN TEMP knob to Off. Remove food from oven.

Oven Vent

The oven vent is located below the back panel. When the oven is in use, this area may feel warm or hot to the touch. To prevent problems, do not block the vent opening in any way.

Oven Racks

The two oven racks are designed with a lock-stop edge to keep the racks from coming completely out of the oven when there is food placed on them.

To remove: Be sure the rack is cool. Pull the rack straight out until it stops. Tilt the front end of the rack up and continue pulling the rack out of the oven.

To replace: Tilt the front end of the rack up and place the rack between the rack supports. Slide it back until it clears the lock-stop position. Lower the front and slide the rack straight in. Pull the rack out to the lock-stop position to be sure it is positioned correctly and then return it to its normal position.

Rack Positions

It is important that air can circulate freely within the oven and around the food. To help insure this, place food in the center of the oven rack. Allow two inches between the edge of the utensil(s) and the oven walls. If cooking on two racks, stagger the food to insure proper airflow.

Do not attempt to change the rack positions when the oven is hot. Use the following guidelines when selecting the proper rack position:

Rack 1: (lowest position)	Used for roasting large cuts of meat and large poultry, frozen pies, souffles, angel food cake, or loaves of bread.
Rack 2:	Used for roasting small cuts of meat, large casseroles, baking loaves of bread, cakes (in either tube, bundt, or layer pans) or two-rack baking.
Rack 3: (middle position)	Used for most baked goods on a cookie sheet or jelly roll pan, or frozen convenience foods.
Rack 4:	Used for most broiling and two-rack baking.
Rack 5: (highest position)	Used for some broiling.

Never place pans directly on the oven bottom. Do not cover an entire oven rack with aluminum foil or place foil directly under a utensil. To catch spillovers, cut a piece of foil a little larger than the pan and place it on the rack below the utensil.

Preheating

Preheating is necessary for proper baking results. It is not necessary for broiling or roasting. Allow the oven to heat until the desired oven temperature is reached (approximately 10-15 minutes).

Selecting a temperature higher than the desired temperature will not preheat the oven any faster. In fact, this may have a negative effect on baking results.

Oven Bottom

To protect the oven bottom against spillovers, use the correct cooking utensil to prevent boilovers. The oven bottom can be removed for cleaning.

To remove: When cool, remove the oven racks. Slide the two catches, located at each rear corner of the oven bottom, toward the front of the oven. Lift the rear edge of the oven bottom slightly, then slide it back until the front edge of the oven bottom clears the oven front frame. Remove the oven bottom from the oven.

To replace: Fit the front edge of the oven bottom into the front frame. Lower the rear of the oven bottom and slide the catches back to lock the oven bottom into place.

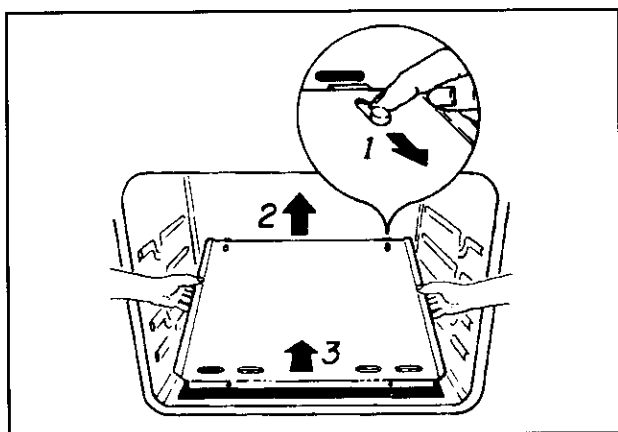

Oven Light

The oven light automatically comes on whenever the oven door is opened. When the door is closed, push the rocker switch marked OVEN LIGHT on the control panel to turn it on or off.

Panel Light

The panel light is turned on by pushing the rocker switch marked PANEL LIGHT on the control panel. It may be turned off by depressing the other side of the switch.

Baking

General Baking Tips

Baking results will generally be best when you use tested recipes from reliable cookbooks. Follow the directions to the letter. Be sure to use fresh ingredients, measure carefully, mix as instructed and use the recommended pan size.

Be sure to preheat the oven if the recipe calls for this (usually done for breads, cookies and biscuits). See the previous section for more information on preheating.

Most recipes provide minimum and maximum baking times such as "bake 35-45 minutes". Do not open the oven door to check the progress until the minimum time has elapsed. Take care not to allow the oven door to slam shut.

Utensils

The finish on baking utensils determines the amount of browning. Colored, glass or dark, rough, dull utensils absorb heat, resulting in a browner, crisper crust. Use this type for pies or breads. For lighter, more delicate browning, use shiny or smooth utensils that reflect heat. These are ideal for cakes and sugar cookies.

When baking in glass utensils, lower the recommended temperature by 25°F. (This is not necessary when baking pies or casseroles.) The same rule applies when using a colored porcelain pan.

Always use the pan size recommended in the recipe. Many pans have the measurements marked on them. If there are no measurements, measure the inside width and length of the pan.

Baking Chart

You may find these guidelines helpful when comparing the baking times, temperatures and oven rack positions of commonly baked foods.

Product & Type	Pan Size	Rack Position*	Temperature	Time**
Cake				
Chocolate, two layers	9"	2, 3 or 4	350°	30-35
Yellow, two layers	9"	2, 3 or 4	350°	30-35
White, two layers	9"	2, 3 or 4	350°	25-30
Bundt	tube	1 or 2	350°	35-45
Cupcakes		2, 3 or 4	350°	15-20
Sheet Cake	15" x 10"	2, 3 or 4	350°	20-25
Angel Food	tube	1	375°	30-40
Pound Cake	loaf	2, 3 or 4	325°	40-50
Snacking Cake	8" x 8"	2, 3 or 4	375°	30-35
Pies				
Two Crust				
Fruit, fresh	9"	2, 3 or 4	400°-425°	35-55
Fruit, frozen	9"	1	400°-425°	45-60
One Crust				
Custard, fresh	9"	2, 3 or 4	350°	35-40
Pie Shell	9"	2, 3 or 4	400°	8-12
Cookies				
Chocolate Chip		2, 3 or 4	350°-375°	8-12
Peanut Butter		2, 3 or 4	350°-375°	8-12
Sugar		2, 3 or 4	350°-375°	8-12
Brownies	8" x 8"	2, 3 or 4	350°	30-40
Breads				
Yeast				
Loaf	loaf	1 or 2	375°	30-40
Rolls		2, 3 or 4	375°-400°	15-20
Quick				
Loaf, nut or fruit	loaf	2, 3 or 4	350°	45-60
Gingerbread	9" x 9"	2, 3 or 4	350°	40
Cornbread	8" x 8"	2, 3 or 4	400°-450°	15-30
Cornbread Muffins		2, 3 or 4	400°	10-20
Biscuits		2, 3 or 4	400°-425°	10-20
Muffins		2, 3 or 4	400°	15-25

*The bottom rack position is #1.

**Times are only approximate and may vary depending on the recipe used.

Temperature Conversions

°Fahrenheit	200	250	275	300	325	350	375	400	425	450
°Celsius	100	120	140	150	160	180	190	200	220	230

Common Baking Problems and Causes

If you have carefully followed the basic instructions and still experience poor results, these suggestions may be helpful.

Problem	Cause	Problem	Cause
Slow baking or roasting.	Baking or roasting time too short. Temperature too low. Oven out of calibration. Old oven out of calibration. Incorrect use of aluminum foil. Oven not preheated. Oven door opened frequently. Too many pans on racks.	Excessive shrinkage.	Too little leavening. Overmixing. Pan too large. Oven temperature too high. Baking time too long. Pans too close to each other or oven wall.
Cakes are uneven.	Pans touching each other or oven walls. Batter uneven in pans. Oven temperature too low or baking time too short. Range not level. Undermixing. Too much liquid.	Crumbly or dry texture.	Improper measurement of sugar, baking powder, liquid or fat. Old baking powder. Oven temperature too high. Baking time too long.
Cakes high in the middle.	Temperature too high. Baking time too long. Overmixing. Too much flour. Pans touching each other or oven walls.	Uneven texture.	Too much liquid. Undermixing. Oven temperature too low. Baking time too short.
Cakes fall.	Too much shortening or sugar. Too much or too little liquid. Temperature too low. Old or too little baking powder. Pan too small. Oven door opened frequently.	Cakes have tunnels.	Not enough shortening. Too much baking powder. Overmixing. Oven temperature too high.
Cakes don't brown on the bottom.	Oven not preheated. Pans darkened, dented or warped.	Cakes crack on the top.	Batter overmixed. Oven temperature too high. Too much leavening.
Cakes don't brown on the top.	Oven temperature too low. Overmixing. Too much liquid. Incorrect pan size or too little batter in pan. Oven door opened too often.	Cakes not done in the center.	Temperature too high. Pan too small.
Cakes, cookies, biscuits too brown on the bottom.	Oven not preheated. Pans touching each other or oven walls. Using glass, darkened, warped or dull finish metal pans. Incorrect rack position. Incorrect use of aluminum foil.	Pie crust edges too brown.	Oven temperature too high. Pans touching each other or oven wall. Edges of crust too thin.
		Pies don't brown on the bottom.	Using shiny metal pans.
		Pies have soaked crust.	Temperature too low at start of baking. Filling too juicy. Using shiny metal pans.

Roasting

Roasting is the method for cooking large, tender cuts of meat uncovered, without adding moisture.

General Tips

Most meats are roasted at 325°F. It is not necessary to preheat the oven. Place the roasting pan on a rack which has been placed in either of the two lowest rack positions.

Use tender cuts of meat weighing three pounds or more. Some good choices are: beef rib, ribeye, top round, high quality tip and rump roast, pork leg and loin roast, veal and lamb leg, shoulder roast and cured and smoked hams.

Season meat, if desired, either before or after roasting. Rub into the surface of the roast if added before cooking.

Place the meat fat-side-up on a rack in a shallow roasting pan. Placing the meat on a rack holds it out of the drippings, thus allowing better heat circulation for even cooking. As the fat on top of the roast melts, the meat is basted naturally, eliminating the need for additional basting.

The cooking time is determined by the weight of the meat and the desired doneness. For more accurate results, use a meat thermometer. Insert it so the tip is in the center of the thickest part of the meat. It should not touch fat or bone.

Remove the roast from the oven when the thermometer registers approximately 5°F below the doneness wanted. As the meat stands, the temperature will rise.

NOTE: For more information on cooking meat and poultry, contact the USDA Meat and Poultry Hotline at 1-800-535-4555.

Roasting Chart (Thawed Meats Only)

Cut of Meat	Approximate Weight (pounds)	Oven Temperature in °F (not preheated)	Internal Temperature	Approximate Roasting Time (min. per pound)*
Beef				
Rib Roast (cut side down)	4 to 8	325°	140° (rare) 160° (medium)	25-30 30-35
Rib Eye Roast	4 to 6	325°	140° (rare) 160° (medium)	25-30 30-35
Loin Tenderloin Roast	2 to 3	400°	140° (rare)	20-25
Top Sirloin Roast	3 to 6	325°	140° (rare) 160° (medium)	25-30 30-35
Pork				
Shoulder Blade Roast, Boneless	4 to 6	325°	160°	35-45
Shoulder Blade Roast	4 to 6	325°	160°	30-40
Loin Blade or Sirloin Roast	3 to 4	325°	160°	35-45
Ham, Half (fully cooked)	5 to 7	325°	140°	25-35
Ham, Half (cook-before-eating)	5 to 7	275°	160°	35-45
Lamb				
Shoulder Roast, Boneless	3-1/2 to 5	325°	160° (medium) 170° (well)	35-40 40-45
Leg, Whole	5 to 7	325°	160° (medium) 170° (well)	30-35 35-40
Veal				
Rib Roast	3 to 5	325°	170°	40-45
Shoulder, Boneless	4 to 6	325°	170°	40-45
Poultry				
Turkey, unstuffed**	12 to 16	325°	180°-185°	18-20
	16 to 20	325°	180°-185°	16-18
	20 to 24	325°	180°-185°	14-16
Turkey, Breast	3 to 8	325°	180°	30-40
Chicken, Fryer	2-1/2 to 3-1/2	375°	185°	20-24
Chicken, Roaster	4 to 6	375°	185°	20-25

*Times are approximate and may vary depending on the type of range used.

**Stuffed turkeys take longer to cook; refer to cookbooks for approximate time.

Broiling

Broiling is a method of cooking used for tender steaks, chops, hamburgers, chicken, fish, and some fruits and vegetables. The food is placed directly under the burner. The degree of doneness is determined by the distance between the meat and the burner, and the length of broiling time.

General Tips

Broiling requires the use of the broiler pan and insert supplied with your range. It is designed to drain excess liquid and fat away from the cooking surface to prevent spatters, smoke and fire.

For easier clean-up, line the broiler pan (bottom piece) with aluminum foil and spray the insert with a non-stick vegetable coating. Do not cover the broiler pan insert with aluminum foil as this prevents fat from draining into the pan below. The broiler can be preheated, however, do not preheat the broiler pan.

To prevent excessive spattering and smoking, trim excess fat from the meat. Increasing the distance between the meat and the heat source will also help.

Broiling Chart

Until you become more familiar with your new range, use the following chart as a guide when broiling foods.

Food	Quantity &/or Thickness	Position	Doneness	Approx. Minutes/Side	
				1st Side	2nd Side
Bacon	thick slice	middle	well	4-5	1-2
Beef Patties	¾" thick	middle	rare	3-4	2-3
		middle	medium	5-6	3-4
		middle	well	5-6	4-5
Steaks	1" thick	bottom	rare	3-4	3-4
		bottom	medium	5-7	4-6
		bottom	well	7-8	6-7
	1½" thick	bottom	rare	7-8	5-6
		bottom	medium	8-10	6-8
		bottom	well	10-11	8-9
Chicken Breast Halves		bottom	well	8-9	7-8
Fish Fillets	1" thick	middle		5-6	3-5
	½" thick	middle		4-5	3-5
Ham Slices (precooked)	½" thick	middle		5-6	4-5
Pork Chops (450°)	1" thick	bottom	well	12-14	8-9
Weiners/Sausage (precooked)		middle		2-4	2-3

The distance from the heat source depends on the thickness of the meat. Thin cuts (¾ to 1 inch) should be placed 2-3 inches from the heat; thicker cuts should be placed 3-5 inches from the heat. Broil until the top of the meat is browned. It should be approximately half cooked by the time the top is browned.

If you plan to season the meat, it is better to do so after the surface has browned. Salt tends to delay browning which can result in overcooking. Salting before cooking also draws the juices out of the meat, causing dryness.

Never leave a soiled broiler pan in the oven after broiling. Drippings might become hot enough to ignite if exposed directly to the burner.

Setting the Controls

1. Before broiling, trim excess fat to prevent excessive spattering or smoking. Cut slashes in the outer edges of the meat to prevent curling during cooking.
2. Turn the OVEN TEMP knob to Broil. Be sure the OVEN SET switch is in the Bake/Broil position.
3. Place the broiler pan on the recommended rack position shown in the broiling chart. If the food is placed too close to the burner, overbrowning and smoking may occur. Generally for a brown exterior and rare interior, the meat should be close to the burner. Place the pan further down if you want the meat well done.
4. Follow the suggested times in the broiling chart. Meat should be turned once about halfway through its cooking time.
5. Check the doneness by cutting a slit in the meat near the center to check the color.

Delay Start Oven Cooking

The delay start cooking feature is used to turn the oven on and off at a preset time-of-day. This feature can be used to delay the start of any cooking operation.

The delay start oven cooking feature will not operate unless the clock is functioning and is set to the correct time-of-day.

IMPORTANT: Highly perishable foods such as dairy products, pork, poultry, seafood, or stuffing are not recommended for delayed cooking. If cooking more than one food, select foods that cook for the same length of time and at the same oven temperature.

To Bake by Time (with immediate start):

1. Place the food in the oven.
2. Press and release the COOK TIME button. 0:00 appears in the display for 3 seconds and the ▼ triangle indicator will light above the COOK TIME button.
3. Enter the cooking time (how long you wish the food to cook) by turning the SET knob. The time will appear in hours and minutes. The  baking symbol light in the display and the ▼ triangle indicator will flash above the OVEN STOP button.
4. Depress the OVEN SET switch to the Timed Bake position and turn the OVEN TEMP knob to the desired temperature. The oven automatically turns on and the display begins to count down the time remaining.
5. An alarm will sound at the end of cooking and the oven will automatically turn off. To turn alarm off, press any button.
6. At the end of cooking, turn the OVEN TEMP knob to Off.

To Cancel:

Turn the SET knob to :00.

Example:

Food is to cook for 1½ hours at 350°F.

1. Press the COOK TIME button.
2. Turn the SET knob until 1:30 (1 hour, 30 minutes) appears in the display.



3. Depress the OVEN SET switch to the Timed Bake position and turn the OVEN TEMP knob to 350°F. The oven will automatically turn on.

To Bake by Time (with delayed start):

1. Place the food in the oven.
2. Press and release the COOK TIME button. 0:00 appears in the display for 3 seconds and the ▼ triangle indicator will light above the COOK TIME button.
3. Enter the cooking time (how long you wish the food to cook) by turning the SET knob. The time will appear in hours and minutes. The  baking symbol will light in the display and the ▼ triangle indicator will flash above the OVEN STOP button.
4. Press and release the OVEN STOP button. The ▼ triangle indicator will light above the OVEN STOP button.
5. Enter the time you wish the oven to turn off by turning the SET knob.
6. Depress the OVEN SET switch to the Timed Bake position and turn the OVEN TEMP knob to the desired temperature. The oven automatically turns on and off at the preset times.
7. An alarm will sound at the end of cooking and the oven will automatically turn off. To turn the alarm off, press any button.
8. At the end of cooking, turn the OVEN TEMP knob to Off.

Example:

Food is to cook for 2½ hours at 350°F. You wish the food to be cooked by 6:00.

1. Press the COOK TIME button.
2. Turn the SET knob until 2:30 (2 hours, 30 minutes) appears in the display.



3. Press the OVEN STOP button.
4. Turn the SET knob until 6:00 appears in the display.
5. Depress the OVEN SET switch to the Timed Bake position.

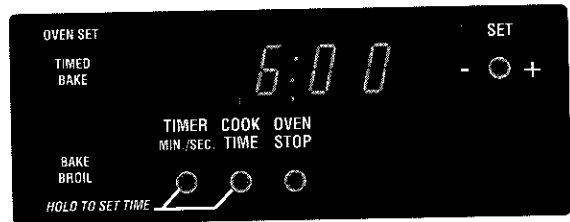

6. Turn the OVEN TEMP knob to 350°F.
- The oven will turn on at 3:30, cook the food for 2½ hours and will automatically turn off at 6:00.

Additional Information:

To cancel a program: Press the COOK TIME button then turn the SET knob until the display reads 0:00. The current time-of-day will reappear in the display. Turn the OVEN TEMP knob to Off.

To check a program: Press the COOK TIME button to see how long food will cook. Press the OVEN STOP button to see what time the oven will turn off.

To prevent accidentally changing the program: Press the TIMER button. The ▼ triangle indicators flash above COOK TIME and OVEN STOP to show that the oven is programmed for a delay start cooking operation.

CARE AND CLEANING

Sealed Gas Burners and Cooktop

WARNING: Wait until the burner cap is cool before cleaning to avoid cracking or crazing of the porcelain.

Sealed Gas Burners

The four sealed burners are secured to the cooktop and are not designed for removal. Since they are sealed into the cooktop, boilovers or spills won't seep underneath the cooktop. Thus, there are no hidden spills to clean.

The burner caps should be cleaned as necessary with soap and water. Do not allow water to enter the gas tube opening. To prevent this, use only a damp, not wet, cloth for cleaning. Plastic or soap-filled scouring pads may also be used for difficult soils.

For burned-on soils, oven cleaner may be used on the porcelain burner caps. Spray the oven cleaner sparingly to prevent it from getting on the other surfaces of the range. Rinse thoroughly.

Clean the gas ports with a straight pin. Do not enlarge or distort the ports. Do not use a wooden toothpick since it may break off and clog the ports.

Porcelain Cooktop

The cooktop on your sealed gas burner range is designed with two contoured wells which contain spills until they can be wiped up. This cooktop does not lift-up nor is it removable. **To prevent damage to the range, do not attempt to lift the cooktop for any reason.**

All spillovers, especially acidic spillovers, should be wiped up as soon as possible with a dry cloth. To prevent possible cracking or chipping of the porcelain, never wipe a warm or hot surface with a damp cloth. Once the surface is cool, clean with warm, sudsy water.

Do not use abrasive or caustic cleaning agents on the porcelain finish for they will permanently damage the finish.

Continuous Clean Oven (select models)

The finish of a continuous clean oven contains a special catalyst and is identified by its dark gray color and its rough, porous texture. The rough texture prevents grease spatters from forming beads which run down the walls leaving unsightly streaks. Rather, the surface absorbs spatters and allows them to spread, thus exposing a larger area to the hot oven air. The catalyst, when exposed to heat, speeds the oxidation of the soil.

The cleaning action automatically begins whenever the oven is turned on for baking or roasting. The oven **must** be used for cleaning to take place – no cleaning will occur when the oven is off. The special catalytic finish must be exposed to hot oven air before the soil will begin to gradually reduce in size.

Factors Affecting Cleaning Time

The length of cleaning time will depend on these factors:

- the type of soil,
- the amount or size of soil,
- the oven temperature, and
- the length of time the oven is in use.

For example, the higher the oven temperature, the faster the cleaning action. In addition, longer baking times will reduce the soil faster than short periods of oven use. Heavy or fresh soils may require continued use of the oven before they fade or can be wiped up manually. The oven will appear presentably clean, even though some spatters may be present.

Manually Cleaning Heavy Spillovers

The continuous clean oven finish will clean most spatters during normal oven use unless there is a heavy buildup of soil. Heavy spillovers such as pie or casserole boilovers will not clean effectively without some manual help. The crusty or varnish-like stains that form from these spillovers clog the pores and prevent the finish from being exposed to the hot oven air. This greatly reduces the cleaning effectiveness of the finish.

These crusty or varnish-like stains must either be removed or broken up before the cleaning can effectively take place.

To remove heavy spillovers: Brush off heavy soil with a nylon brush or plastic pad. **Do not use paper towels, cloths or sponges** because the oven walls are rough and particles of these materials will rub off on the walls. Rinse the area with clear water only.

Hints

Brittle crusts or stains can be loosened by gently tapping the stain with a wooden or plastic utensil. Brush away any loose soil that flakes off. Varnish-like stains usually need to be softened with a small amount of water or a damp cloth. Any remaining soil will gradually reduce with continued oven use at normal baking temperatures.

NOTE: Do not use any type of oven cleaner, powdered cleansers, soap, detergent or paste on any continuous cleaning surface. Also, do not use any abrasive materials, steel wool, sharp instruments or scrapers because they will damage the finish.

Avoid spillovers by using utensils that are large enough to hold the food. A cookie sheet or piece of aluminum foil, just a little larger than the pan, can be placed on the rack directly below the rack holding the utensil to catch spills.

Over a period of time, wear marks may appear on the embossed rack supports. This is normal and results from sliding the racks in and out of the oven. Wear marks will not affect the cleaning action of the oven.

Manual Clean Oven (select models)

You may clean the porcelain enamel oven interior of your Maytag range using a commercial oven cleaner. Be sure to follow all the package instructions and avoid getting the oven cleaner on any of the other surfaces of the range.

Your oven may also be cleaned with warm sudsy water, mild abrasive cleaners and plastic scouring pads. Do not use metallic scouring pads because they can scratch the surface. Never wipe a warm or hot surface with a damp cloth as cracking and chipping may result.

For more information on cleaning your Maytag range, refer to the cleaning chart on pages 19-20.

RANGE CLEANING CHART

Cleaning Agents*

Many different cleaning agents are recommended for the various parts of the ranges. The following brand names may help you to make an appropriate selection:

1. Mild abrasive cleaners such as Bon Ami, Soft Scrub, Bar Keepers Friend, Cameo.
2. Mild liquid sprays such as Fantastik, Formula 409.
3. Glass cleaner such as Windex, Glass Plus.
4. Plastic and nylon scouring pads.

DO NOT USE abrasive cleansing powders such as Comet or Zud, soap-filled scouring pads like S.O.S. or Brillo, commercial oven cleaners, or an automatic dishwasher **except when indicated.**

Be certain all range parts are cool before handling to avoid damage.

*Brand names of cleaning agents are trademarks of the respective manufacturers.

Part	Cleaning Agents	Tips and Precautions
Baked Enamel: Side Panels Control Panel Broiler Drawer	Soap and water Mild liquid sprays Glass cleaners	Wash, rinse, dry with soft cloth. Do not use oven cleaner or abrasive agents.
Broiler Pan and Insert	Soap and water Plastic or soap-filled scouring pads Dishwasher	Pretreat the broiler pan and insert with a non-stick vegetable coating such as Pam or Mazola to make cleaning easier. Soaking makes cleaning easier.
Burner Grates	Soap and water Soap-filled scouring pads Dishwasher	
Control Knobs	Soap and water Mild liquid sprays Glass cleaners	Wash, rinse, dry with soft cloth. For ease of cleaning, remove knobs by pulling forward.
Glass Oven Door	Soap and water Glass cleaners	Avoid using excessive amounts of water which may seep behind the glass.
Metal Finishes and Trim	Soap and water Mild abrasive cleaners	Do not use oven cleaner or abrasive agents. Remove stubborn soil with a paste of mild abrasive cleaner and water. Polish with a soft cloth.

Continued on next page

Range Cleaning Chart (continued)

Part	Cleaning Agents	Tips and Precautions
<p>Oven Interior Continuous Clean (select models)</p> <p>Manual Clean (select models)</p>	<p>Cleaning action begins whenever the oven is on. The oven must be used for cleaning to take place. Higher oven temperatures and longer baking times speed the cleaning action.</p> <p>Soap and water Mild abrasive cleaners and plastic pads Commercial oven cleaner</p>	<p>Brush off heavy soil with a nylon or plastic pad. Do not use paper towels, cloths, or sponges because the oven walls are porous and particles of these materials will rub off on the walls. Rinse area with clean water only. Do not use any type of oven cleaner, cleanser or detergent on this surface.</p> <p>Do not use metallic scouring pads because they will scratch the surface. When using commercial oven cleaners follow the manufacturer's instructions.</p>
Oven Racks	<p>Soap and water Plastic scouring pads Cleansing powders Soap-filled scouring pads</p>	If racks become difficult to slide, a thin coat of vegetable oil on the underside of the rack will make sliding easier.
<p>Plastic Finishes: Door Handle Control Panel Trim Endcaps Manifold Panel</p>	<p>Soap and water Mild liquid sprays</p>	Do not use abrasive cleansers.
Porcelain Enamel Top and Back Panel	<p>Soap and water Mild abrasive cleaners Mild liquid sprays</p>	<p>Wipe up all spillovers immediately with a dry cloth – especially acid spills (milk, fruits, tomato, etc.). Never wipe a warm or hot surface with a damp cloth as cracking and chipping may result.</p>
Sealed Gas Burners	<p>Soap and water Plastic scouring pads Soap-filled scouring pads</p>	<p>Wait until the cap cools before cleaning. Cleaning a hot burner cap may cause the porcelain to crack. Do not allow water or cleaning agents to enter the gas tube opening. To prevent this, use only a damp, not wet, cloth for cleaning. For burned-on or difficult soil, oven cleaner may be used on the porcelain burner caps. Spray sparingly to prevent cleaner from getting on the other surfaces of the range. Rinse thoroughly.</p>

MAINTENANCE

Electrical Connection

Appliances which require electrical power are equipped with a three-prong grounding plug which must be plugged directly into a properly grounded three-hole 120 volt electrical outlet.

If an ungrounded, two-hole or other type electrical outlet is encountered, **it is the personal responsibility of the appliance owner to have receptacle replaced with a properly grounded three hole electrical outlet.** The three-prong grounding plug is provided for protection against shock hazards. **Do not cut or remove the third grounding prong from the power cord plug.**

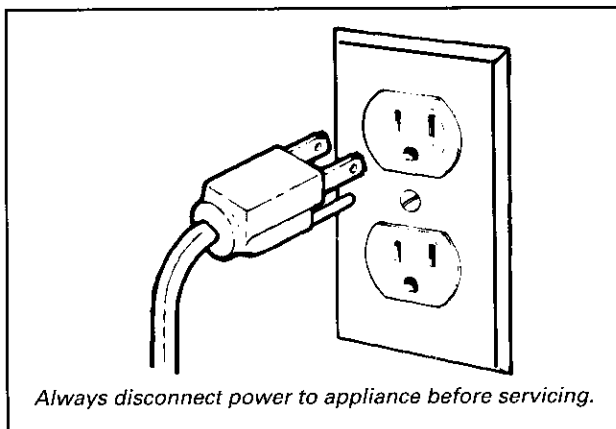

Leveling Legs

Some floors are not level. For proper baking, your range must be level. The leveling legs are located on each corner of the base of the range. Level the range by turning the legs.

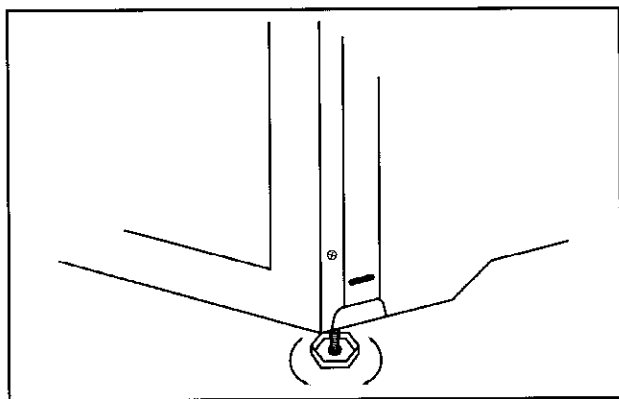

WARNING: To reduce the risk of accidental tipping of the range, it must be secured by a properly installed anti-tip device. To check if the device is installed properly, use a flashlight and look underneath the range to see that one of the rear leveling legs is engaged in the bracket slot. The anti-tip device secures the rear leveling leg to the floor, if properly engaged.

Light Replacement

Before replacing the light bulb, **disconnect the power to the range.** Be sure the bulb is cool. Do not touch a hot bulb with a damp cloth as the bulb may break.

To Replace Panel Light

Grasp the top trim of the backpanel with your thumbs under the front edge and pull outward while lifting to release the trim from the catches at each end. Remove the bulb and replace it with an 18 watt fluorescent tube. Snap the top trim back into place and restore the power. Reset the clock to the current time-of-day.

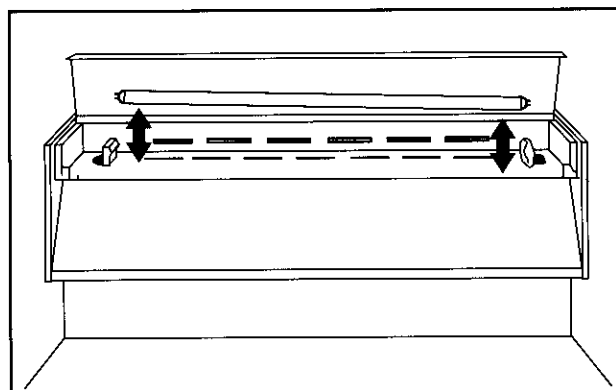

To Replace Oven Light

Very carefully unscrew the lens cover with a dry potholder to prevent possible harm to hands, then very carefully remove the bulb with a dry potholder. Replace with a 40 watt appliance bulb. Reconnect the power to the range and reset the clock to the current time-of-day.

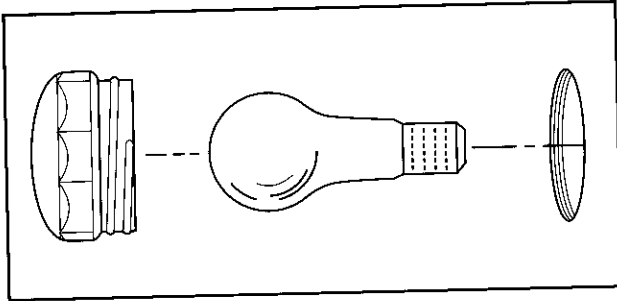

Oven Door

Do not place excessive weight on an open oven door or stand on an open oven door as, in some cases, it could damage the door, cause the range to tip over and possibly injure the user.

When opening the oven door, allow steam and hot air to escape before reaching into the oven to check, add or remove food.

To Remove Lift-Off Door

Open the door to the first stop position (opened about 4-6 inches) and grasp the door with both hands at each side. Do not use the door handle to lift the door. Lift up evenly until the door clears the hinge arms.

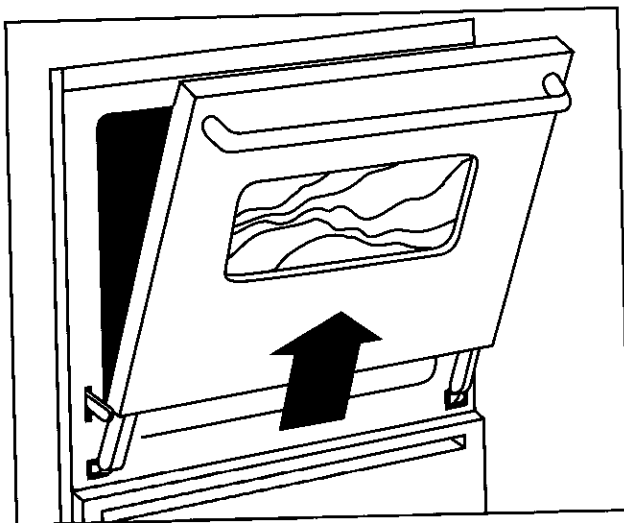

CAUTION: The hinge arms are spring-mounted and will slam shut against the range if accidentally hit. **Never place your hand or fingers between the hinges and the front oven frame.** You could be injured if the hinge snaps back.

To Replace Door

Grasp the door at each side, align the slots in the door with the hinge arms and slide the door down onto the hinge arms until it is completely seated on the hinges.

Do not attempt to open or close the door until the door is completely seated on the hinge arms. Never turn the oven on unless the door is properly in place. When baking, be sure the door is completely closed. Your baking results will be affected if the door is not securely closed.

Proportional Valve Adjustment

The LOW setting should produce a stable flame when turning the knob from HIGH to LOW. The flame should be 1/8 inch or lower and must be stable on all ports on LOW setting.

To adjust: Operate burner on HIGH for about 5 minutes to preheat burner cap. Turn knob back to LOW; remove knob, and insert a small screwdriver into the center of the valve stem. Adjust flame size by turning adjustment screw in either direction. Flame must be of sufficient size to be stable on all burner ports. If flame adjustment is needed, adjust **ONLY** on the LOW setting. Never adjust flame size on a higher setting.

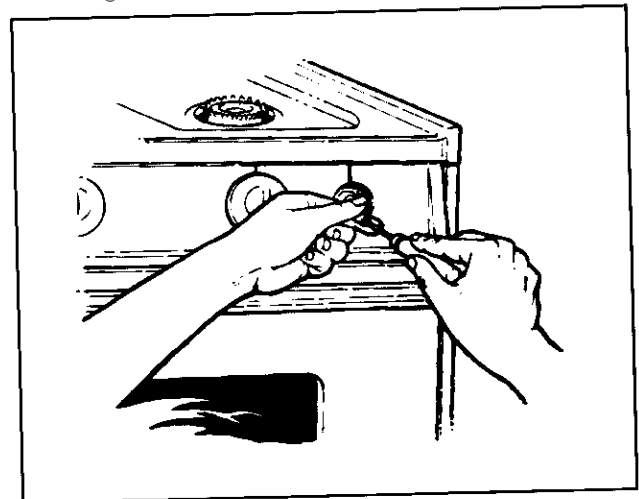

NOTE: All gas adjustments should be done by a qualified servicer only.

Removing Range for Cleaning and Servicing

When necessary, follow these procedures to remove the appliance for cleaning or servicing:

1. Shut off the gas supply to the appliance.
2. Disconnect the electrical supply to the appliance.
3. Disconnect the gas supply tubing to the appliance.
4. Slide the range forward to disengage the range from the anti-tip bracket. (See the Installation Instructions for location of the bracket.)
5. Reverse the procedure to reinstall. If the gas line has been disconnected, check for gas leaks after reconnection. (See the Installation Instructions for the gas leak test method.)

Broiler Drawer

Store a clean broiler pan and insert in the broiler drawer.

To Remove the Drawer

Pull the drawer out to the first stop position. Lift up the front of the drawer and pull it to the second stop position. Grasp the sides and lift up and out to remove the drawer.

To Replace the Drawer

Fit the ends of the drawer glides onto the rails. Lift up the drawer front and gently push in to the first stop position. Lift up the drawer again and continue to slide the drawer to the closed position.

BEFORE YOU CALL FOR SERVICE

Check these points if . . .

Part or all of your gas range does not operate

- Is the range plug loose or disconnected from the electrical outlet (if not wired direct to the electrical supply)?
- Is the gas supply connected or turned on?
- Are any house fuses blown or circuit breakers tripped?
- Has the power or gas supply to the home been interrupted?
- Are the oven controls properly set?
- Was the electronic control (select models) correctly set?
- Is the oven set for delay start? (select models)

Surface burner fails to light or is unstable

- Are any burner ports clogged?
- Is the burner properly positioned?
- Is the pilot light out (pilot model)?
- Is the range plug disconnected from the electrical outlet (if not wired direct to the electrical supply)?

Food not baking correctly

- Are the oven racks properly placed for baking? (see Baking Chart)
- Have you used aluminum foil correctly?
- Was the oven preheated as recommended?
- Are the controls for bake operations properly set?

- Are the range and oven racks level?
- Was good cookware/bakeware of the proper size used?
- Are you using a tested recipe from a reliable source? The oven thermostat on your new range may be more accurate than the one on your old range.
- Is there 1-2 inches of space between pans and the oven sides?
- Is the oven bottom positioned correctly?
- Was the oven vent covered or blocked on the range surface?

Food does not broil properly

- Are the controls for broiling set properly? (see Broiling section)
- Was the proper rack position used? (see Broiling section)
- Was the broiler pan provided with the range used?
- Was aluminum foil used on the broiler pan insert, blocking the slits for fat drainage?

Oven light does not operate

- Is the bulb loose or burned out?
- Is the light switch in the On position?

CONSUMER PUBLICATIONS

For more information, order the following booklets from Maytag at the prices indicated. Send your name, address, booklet title, form number and payment to: Consumer Education Dept., Maytag Company, One Dependability Square, Newton, IA 50208. Allow 4-6 weeks for delivery.

- Cooking Made Simple - 272YG50¢
- Taking the Lid Off Cooktop Choices - 298YG50¢
- Before You Call (avoiding unnecessary service calls) - 206YG50¢
- Appliance Buying Guides50¢ EACH
 - Washer — 211YG
 - Dryer — 212YG
 - Dishwasher — 213YG
 - Electric Range — 214YG
 - Gas Range — 215YG

RANGE WARRANTY

Full One Year Warranty

For one (1) year from the date of original retail purchase, any part which fails in normal home use will be repaired or replaced free of charge.

Limited Warranty

After the first year from the date of original retail purchase, through the second year, parts which fail in normal home use will be repaired or replaced free of charge for the part itself, with the owner paying all other costs, including labor, when the appliance is located in the United States or Canada.

Electric Heating Elements: After the second year from the date of original retail purchase, through the fifth year, all surface elements (solid disc, coil and smooth top), glass cooking surfaces, broil elements and oven bake elements on electric ranges, which fail in normal home use will be repaired or replaced free of charge for the part itself, with the owner paying all other costs, including labor, when the appliance is located in the United States or Canada.

Sealed Gas Burners: After the second year from the date of original retail purchase, through the tenth year, sealed gas burners on gas ranges, which fail in normal home use will be repaired or replaced free of charge for the part itself, with the owner paying all other costs, including labor, when the appliance is located in the United States or Canada.

Canadian Residents

This warranty covers only those appliances installed in Canada that have been listed with Canadian Standards Association unless the appliances are brought into Canada due to transfer of residence from the United States to Canada.

Limited Parts Warranty Outside The United States Or Canada

For two (2) years from the date of original retail purchase, any part which fails in normal home use will be repaired or replaced free of charge for the part itself, with the owner paying all other costs, including labor, when the appliance is located outside the United States or Canada.

This Warranty gives you specific legal rights, and you may also have other rights which vary from state to state.

To Receive Warranty Service

First: To locate an authorized service company in your area, contact the Maytag dealer from whom your appliance was purchased or call Maytag Customer Assistance:

US 1-800-688-9900

CANADA 1-800-688-2002

or check in your telephone directory yellow pages.

Second: Should you not receive satisfactory warranty service from the dealer or authorized service firm, or need further assistance, call or write:

Maytag Customer Assistance
c/o Maycor Appliance Parts and Service Co.
A division of Maytag Corporation
P.O. Box 2370
Cleveland, TN 37311

US 1-800-688-9900

CANADA 1-800-688-2002

When contacting Customer Assistance be sure to provide the model and serial number of your appliance, the name and address of the dealer from whom you purchased the appliance, and the date of purchase.

Should you still have a problem, write to: Major Appliance Consumer Action Panel, 20 North Wacker Drive, Chicago, Illinois 60606. MACAP is an industry sponsored but independent group of consumer experts who receive and act on complaints from appliance owners.

NOTE: When writing about an unsolved service problem, please include the following information:

- (a) Your name, address and telephone number;
- (b) Model number and serial number (found on the data plate located on the frame around the storage drawer) of your appliance;
- (c) Name and address of your dealer and date the appliance was bought;
- (d) A clear description of the problem you are having.

MAYTAG COMPANY • Newton, Iowa 50208